

# 1000BASE-T SFP Copper Transceiver

## Hot Pluggable, 1.25Gb/s,Cat-5 UTP Cable, 100m



### Features:

- ✧ Up to 1.25Gb/s bi-directional data links
- ✧ Hot-pluggable SFP footprint
- ✧ Extended case temperature range (-40°C to +85°C )
- ✧ Fully metallic enclosure for low EMI
- ✧ Low power dissipation
- ✧ Compact RJ-45 connector assembly

- ✧ Detailed product information in EEPROM
- ✧ +3.3V single power supply
- ✧ Access to physical layer IC via 2-wire serial bus
- ✧ Compliant with SFP MSA
- ✧ Compliant with IEEE Std 802.3TM-2002
- ✧ Compliant with FCC 47 CFR Part 15, Class B
- ✧ RoHS Compliant Products

### Applications:

- ✧ 1.25 Gigabit Ethernet over Cat 5 cable
- ✧ Switch/Router to Switch/Router Link
- ✧ High speed I/O for file servers

### Description:

TSPT01G 1000BASE-T copper SFP transceiver is high performance, cost effective module compliant with the Gigabit Ethernet and 1000BASE-T standards as specified in IEEE 802. 3-2002 and IEEE 802.3ab, which supporting 1000Mbps data- rate up to 100 meters reach over unshielded twisted-pair category 5 cable. The TSPT01G supports 1000 Mbps full duplex data-links with 5-level Pulse Amplitude Modulation (PAM) signals. All four pairs in the cable are used with symbol rate at 250Mbps on each pair. The TSPT01G provides standard serial ID information compliant with SFP MSA, which can be accessed with address of A0h via the 2-wire serial CMOS EEPROM protocol. The physical IC can also be accessed via 2-wire serial bus at address ACh.

### Order Information

| OP34 | XX                       | X  | X   | X   | X  |
|------|--------------------------|--|---|---|--|
|      | <b>Reach:</b><br>01:100M | <b>Data Rate:</b><br>blank=10/100/1000Mb/S<br>G=1000Mb/S | <b>Temp Range:</b><br>blank=0~70°C<br><br>E=-5~85°C<br><br>I=-40~85°C | <b>Auto-Neg:</b><br>blank=EN Auto-Neg<br>D=DIS Auto-Neg | <b>LOS:</b><br>blank=with LOS<br>N=without LOS(LOS to GND) |

### Example

**1000BASE-T SFP Copper Transceiver**  
**Hot Pluggable, 1.25Gb/s,Cat-5 UTP Cable, 100m**

| Part No.  | Data Rate (Mbps)   | Reach (km) | Temperature |
|-----------|--|------------|-------------|
| TSPT01G   | 1000BASE-T, with SERDES interface, enable the auto-negotiation default, support Rx_LOS as link indication function                               | 0.1        | -40°C~85°C  |
| TSPT01GD  | 1000BASE-T, with SERDES interface, disable the auto-negotiation default, support Rx_LOS as link indication function                              | 0.1        | -40°C~85°C  |
| TSPT01GN  | 1000BASE-T, with SERDES interface, enable the auto-negotiation default, does not have a link indication feature (RX_LOS is internally grounded)  | 0.1        | -40°C~85°C  |
| TSPT01GDN | 1000BASE-T, with SERDES interface, disable the auto-negotiation default, does not have a link indication feature (RX_LOS is internally grounded) | 0.1        | -40°C~85°C  |

**SFP to Host Connector Pin Out**

| Pin | Signal name | Description                                       | MSA Notes |
|-----|-------------|---|-----------|
| 1   | VEET        | Transmitter ground (common with receiver ground)  |           |
| 2   | TFAULT      | Transmitter Fault. Not supported                  | Note 1    |
| 3   | TDIS        | Transmitter Disable. PHY disabled on high or open | Note 2    |
| 4   | MOD_DEF(2)  | Module Definition 2. Data line for Serial ID.     | Note 3    |
| 5   | MOD_DEF(1)  | Module Definition 1. Clock line for Serial ID.    | Note 3    |
| 6   | MOD_DEF(0)  | Module Definition 0. Grounded within the module.  | Note 3    |

**1000BASE-T SFP Copper Transceiver**  
**Hot Pluggable, 1.25Gb/s,Cat-5 UTP Cable, 100m**

|    |             |  |        |
|----|-------------|--|--------|
| 7  | Rate Select | No connection required                           |        |
| 8  | LOS         | Loss of Signal - High Indicates Loss of Signal   |        |
| 9  | VEER        | Receiver Ground (common with transmitter ground) |        |
| 10 | VEER        | Receiver Ground (common with transmitter ground) |        |
| 11 | VEER        | Receiver Ground(common with transmitter ground)  |        |
| 12 | RD-         | Receiver Inverted DATA out. AC Coupled           | Note 4 |
| 13 | RD+         | Receiver Non-inverted DATA out. AC Coupled       | Note 4 |
| 14 | VEER        | Receiver Ground (common with transmitter ground) |        |
| 15 | VCCR        | Receiver Power Supply                            | Note 5 |
| 16 | VCCT        | Transmitter Power Supply                         | Note 5 |
| 17 | VEET        | Transmitter Ground (Common with Receiver Ground) |        |
| 18 | TD+         | Transmitter Non-Inverted DATA in. AC Coupled.    | Note 6 |
| 19 | TD-         | Transmitter Inverted DATA in. AC Coupled.        | Note 6 |
| 20 | VEET        | Transmitter Ground(common with receiver ground)  |        |

Table 1. SFP to host connector pin assignments and descriptions

**Notes:**

- TX Fault is not used and is always tied to ground through a 100 ohm resistor.
- TX Disable as described in the MSA is not applicable to the 1000BASE-T module, but is used for convenience as an input to reset the internal ASIC. This pin is pulled up within the module with a 4.7 K resistor.  
 Low (0 – 0.8 V): Transceiver on  
 Between (0.8 V and 2.0 V): Undefined  
 High (2.0 – 3.465 V): Transceiver in reset state  
 Open: Transceiver in reset state
- Mod-Def 0,1,2. These are the module definition pins. They should be pulled up with a 4.7-10 K resistor on the host board to a supply less than VCCT + 0.3 V or VCCR + 0.3 V.  
 Mod Def 0 is tied to ground through a 100 ohm resistor to indicate that the module is present.  
 Mod-Def 1 is clock line of two wire serial interface for optional serial ID  
 Mod-Def 2 is data line of two wire serial interface for optional serial ID
- RD-/+: These are the differential receiver outputs. They are ac coupled 100 ohm differential lines which should be terminated with 100 ohm differential at the user SerDes. The ac coupling is done inside the module and is thus not required on the host board. The voltage swing on these lines will be between 370 and 2000 mV differential (185 – 1000 mV single ended) when properly terminated. These levels are compatible with CML and LVPECL voltage swings.
- VCCR and VCCT are the receiver and transmitter power supplies. They are defined as 3.3 V ± 5% at the SFP connector pin. The maximum supply current is about 300mA and the associated in-rush current will typically be no more than 30 mA above steady state after 500 nanoseconds.
- TD-/+: These are the differential transmitter inputs. They are ac coupled differential lines with 100 W differential termination inside the module. The ac coupling is done inside the module and is thus not required on the host board. The inputs will accept differential swings of 500 – 2400 mV (250 –1200 mV single ended), though it is recommended that values between 500 and 1200 mV differential (250 – 600 mV single ended) be used for best EMI performance. These levels are compatible with CML and LVPECL voltage swings.

# 1000BASE-T SFP Copper Transceiver

## Hot Pluggable, 1.25Gb/s, Cat-5 UTP Cable, 100m

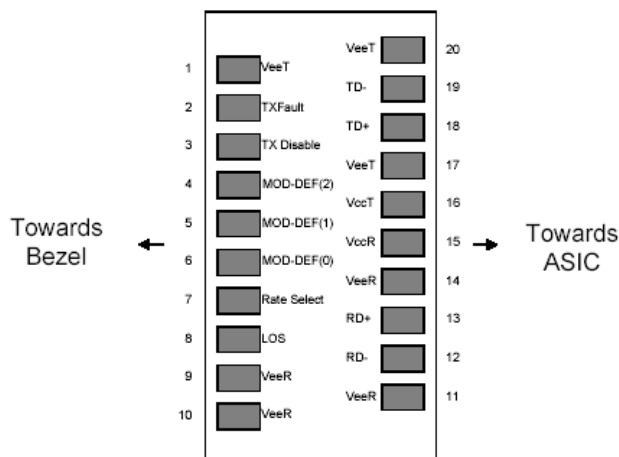

**Figure 1. Diagram of host board connector block pin numbers and names**

### +3.3V Volt Electrical Power Interface

The TSPT01G has an input voltage range of 3.3 V +/- 5%. The 4 V maximum voltage is not allowed for continuous operation.

| Parameter      | Symbol | Min. | Typical | Max. | Units | Notes/Conditions  |
|----------------|--------|------|---------|------|-------|---|
| Supply Current | Is     |      | 320     | 375  | mA    | 1.2W max power over full range of voltage and temperature. See caution note below |
| Input Voltage  | Vcc    | 3.13 | 3.3     | 3.47 | V     | Referenced to GND   |
| Surge Current  | Isurge |      | 30      |      | mA    | Hot plug above steady state current. See caution note                             |

Caution: Power consumption and surge current are higher than the specified values in the SFP MSA

**Table 2. +3.3 Volt electrical power interface**

### Low-Speed Signals

MOD\_DEF(1) (SCL) and MOD\_DEF(2) (SDA), are open drain CMOS signals. Both MOD\_DEF(1) and MOD\_DEF(2) must be pulled up to host\_Vcc.

| Parameter       | Symbol | Min.          | Max.           | Units | Notes/Conditions                 |
|-----------------|--------|---------------|----------------|-------|----------------------------------|
| SFP Output LOW  | VOL    | 0             | 0.5            | V     | 4.7k to 10k pull-up to host_Vcc. |
| SFP Output HIGH | VOH    | host_Vcc -0.5 | host_Vcc + 0.3 | V     | 4.7k to 10k pull-up to host_Vcc. |
| SFP Input LOW   | VIL    | 0             | 0.8            | V     | 4.7k to 10k pull-up to Vcc.      |
| SFP Input HIGH  |        | 2             | Vcc + 0.3 V    | V     | 4.7k to 10k pull-up to Vcc.      |

**Table 3. Low-speed signals, electronic characteristics**

### High-Speed Electrical Interface

# 1000BASE-T SFP Copper Transceiver

## Hot Pluggable, 1.25Gb/s,Cat-5 UTP Cable, 100m

All high-speed signals are AC-coupled internally.

### Transmission Line-SFP

| Parameter           | Symbol  | Min. | Typical | Max. | Units | Notes/Conditions                 |
|---------------------|---------|------|---------|------|-------|----------------------------------|
| Line Frequency      | fL      |      | 125     |      | MHz   | 5-level encoding, per IEEE 802.3 |
| Tx Output Impedance | Zout,TX |      | 100     |      | Ohm   | Differential                     |
| Rx Input Impedance  | Zin,RX  |      | 100     |      | Ohm   | Differential                     |

**Table 4. High-speed electrical interface, transmission line-SFP**

### Host-SFP

| Parameter                      | Symbol   | Min. | Typical | Max. | Units | Notes/Conditions |
|--------------------------------|----------|------|---------|------|-------|------------------|
| Single ended data input swing  | Vinsing  | 250  |         | 1200 | mV    | Single ended     |
| Single ended data output swing | Voutsing | 350  | 100     | 800  | mV    | Single ended     |
| Rise/Fall Time                 | Tr,Tf    |      | 175     |      | psec  | 20%-80%          |
| Tx Input Impedance             | Zin      |      | 50      |      | Ohm   | Single ended     |
| Rx Output Impedance            | Zout     |      | 50      |      | Ohm   | Single ended     |

**Table 5. High-speed electrical interface, host-SFP**

### General Specifications

| Parameter    | Symbol | Min. | Typical | Max.  | Units | Notes/Conditions           |
|--------------|--------|------|---------|-------|-------|----------------------------|
| Data Rate    | BR     | 100  |         | 1,000 | Mb/s  | IEEE 802.3 compatible.     |
| Cable Length | L      |      |         | 100   | m     | Category 5 UTP. BER <10-12 |

**Table 6. General specifications**

### Notes:

1. Clock tolerance is +/- 50 ppm
2. By default, the TSPT01G is a full duplex device in preferred master mode
3. Automatic crossover detection is enabled. External crossover cable is not required
4. 10/100/1000 BASE-T operation requires the host system to have an SGMII interface with no clocks, With a SERDES that does not support SGMII, the module will operate at 1000BASE-T only.

### Environmental Specifications

The TSPT01G has an extended range from 0°C to +85°C case temperature as specified in Table 7.

| Parameter             | Symbol | Min. | Typical | Max. | Units | Notes/Conditions    |
|-----------------------|--------|------|---------|------|-------|---------------------|
| Operating Temperature | Top    | -40  |         | 85   | °C    | Case temperature    |
| Storage Temperature   | Tsto   | -40  |         | 100  | °C    | Ambient temperature |

**1000BASE-T SFP Copper Transceiver**  
**Hot Pluggable, 1.25Gb/s,Cat-5 UTP Cable, 100m**

**Serial ID Memory Contents:**

| <b>Data Address</b>       | <b>Length (Byte)</b> | <b>Name of Length</b> | <b>Description and Contents</b>  |
|---------------------------|----------------------|-----------------------|--|
| Base ID Fields            |                      |                       |  |
| 0                         | 1                    | Identifier            | Type of Serial transceiver (03h=SFP)   |
| 1                         | 1                    | Reserved              | Extended identifier of type serial transceiver (04h)   |
| 2                         | 1                    | Connector             | Code of optical connector type (22=RJ45)   |
| 3-10                      | 8                    | Transceiver           | 1000BASE-T   |
| 11                        | 1                    | Encoding              | 8B10B (01h)  |
| 12                        | 1                    | BR,Nominal            | Nominal baud rate, unit of 100Mbps   |
| 13                        | 1                    | Reserved              | (0000h)  |
| 14                        | 1                    | Length(9um,km)        | Link length supported for 9/125um fiber, units of km   |
| 15                        | 1                    | Length(9um)           | Link length supported for 9/125um fiber, units of 100m   |
| 16                        | 1                    | Length(50um)          | Link length supported for 50/125um fiber, units of 10m   |
| 17                        | 1                    | Length(62.5um)        | Link length supported for 62.5/125um fiber, units of 10m   |
| 18                        | 1                    | Length(Copper)        | Link length supported for copper, units of meters  |
| 19                        | 1                    | Reserved              |  |
| 20-35                     | 16                   | Vendor Name           | SFP vendor name:   |
| 36                        | 1                    | Reserved              |  |
| 37-39                     | 3                    | Vendor OUI            | SFP transceiver vendor OUI ID  |
| 40-55                     | 16                   | Vendor PN             | Part Number: "OPXXXXXX" (ASCII)  |
| 56-59                     | 4                    | Vendor rev            | Revision level for part number   |
| 60-61                     | 2                    | Wavelength            | Laser wavelength   |
| 62                        | 1                    | Reserved              |  |
| 63                        | 1                    | CCID                  | Least significant byte of sum of data in address 0-62  |
| Extended ID Fields        |                      |                       |  |
| 64-65                     | 2                    | Option                | Indicates which optical SFP signals are implemented(001Ah = LOS, TX_FAULT, TX_DISABLE all supported) |
| 66                        | 1                    | BR, max               | Upper bit rate margin, units of %  |
| 67                        | 1                    | BR, min               | Lower bit rate margin, units of %  |
| 68-83                     | 16                   | Vendor SN             | Serial number (ASCII)  |
| 84-91                     | 8                    | Date code             | Manufacturing date code  |
| 92-94                     | 3                    | Reserved              |  |
| 95                        | 1                    | CCEX                  | Check code for the extended ID Fields (addresses 64 to 94)   |
| Vendor Specific ID Fields |                      |                       |  |
| 96-127                    | 32                   | Readable              | Vendor specific date, read only  |

**1000BASE-T SFP Copper Transceiver**  
**Hot Pluggable, 1.25Gb/s, Cat-5 UTP Cable, 100m**

---

**Mechanical drawing:**

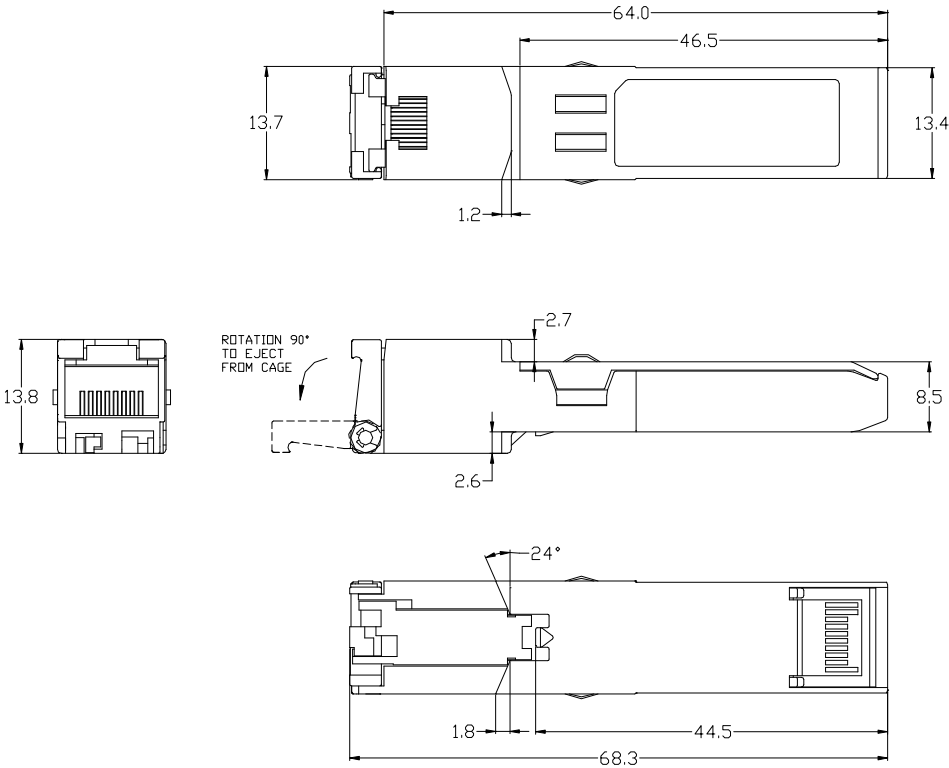

**Figure 2. Mechanical Dimensions of Transceiver**